

Oracle Banking Digital Experience

**Corporate Bill Payments User Manual
Release 18.3.0.0.0**

Part No. F12056-01

December 2018

ORACLE®

Corporate Bill Payments User Manual
December 2018

Oracle Financial Services Software Limited
Oracle Park
Off Western Express Highway
Goregaon (East)
Mumbai, Maharashtra 400 063
India

Worldwide Inquiries:

Phone: +91 22 6718 3000

Fax: +91 22 6718 3001

www.oracle.com/financialservices/

Copyright © 2018, Oracle and/or its affiliates. All rights reserved.

Oracle and Java are registered trademarks of Oracle and/or its affiliates. Other names may be trademarks of their respective owners.

U.S. GOVERNMENT END USERS: Oracle programs, including any operating system, integrated software, any programs installed on the hardware, and/or documentation, delivered to U.S. Government end users are “commercial computer software” pursuant to the applicable Federal Acquisition Regulation and agency-specific supplemental regulations. As such, use, duplication, disclosure, modification, and adaptation of the programs, including any operating system, integrated software, any programs installed on the hardware, and/or documentation, shall be subject to license terms and license restrictions applicable to the programs. No other rights are granted to the U.S. Government.

This software or hardware is developed for general use in a variety of information management applications. It is not developed or intended for use in any inherently dangerous applications, including applications that may create a risk of personal injury. If you use this software or hardware in dangerous applications, then you shall be responsible to take all appropriate failsafe, backup, redundancy, and other measures to ensure its safe use. Oracle Corporation and its affiliates disclaim any liability for any damages caused by use of this software or hardware in dangerous applications.

This software and related documentation are provided under a license agreement containing restrictions on use and disclosure and are protected by intellectual property laws. Except as expressly permitted in your license agreement or allowed by law, you may not use, copy, reproduce, translate, broadcast, modify, license, transmit, distribute, exhibit, perform, publish or display any part, in any form, or by any means. Reverse engineering, disassembly, or decompilation of this software, unless required by law for interoperability, is prohibited.

The information contained herein is subject to change without notice and is not warranted to be error-free. If you find any errors, please report them to us in writing.

This software or hardware and documentation may provide access to or information on content, products and services from third parties. Oracle Corporation and its affiliates are not responsible for and expressly disclaim all warranties of any kind with respect to third-party content, products, and services. Oracle Corporation and its affiliates will not be responsible for any loss, costs, or damages incurred due to your access to or use of third-party content, products, or services.

Table of Contents

1. Preface	4
1.1 Intended Audience	4
1.2 Documentation Accessibility	4
1.3 Access to Oracle Support	4
1.4 Structure.....	4
1.5 Related Information Sources.....	4
2. Transaction Host Matrix	5
3. Electronic Bill Presentment And Payment	6
4. Bills	7
4.1 Bills - Summary	8
4.2 Pay Bills - Presentment Type.....	11
4.3 Pay Bills - Payment Type	15
4.4 Pay Bills - Presentment and Payment Type	18
4.5 Pay Bills - Recharge Type.....	22
5. Add Biller	26
6. Manage Billers	31
6.2 Manage Billers - Delete.....	38
7. Quick Bill Pay	41
8. Quick Recharge	46
9. Payment History	52
10. Alerts	55

1. Preface

1.1 Intended Audience

This document is intended for the following audience:

- Customers
- Partners

1.2 Documentation Accessibility

For information about Oracle's commitment to accessibility, visit the Oracle Accessibility Program website at <http://www.oracle.com/pls/topic/lookup?ctx=acc&id=docacc>.

1.3 Access to Oracle Support

Oracle customers have access to electronic support through My Oracle Support. For information, visit

<http://www.oracle.com/pls/topic/lookup?ctx=acc&id=info> or visit

<http://www.oracle.com/pls/topic/lookup?ctx=acc&id=trs> if you are hearing impaired.

1.4 Structure

This manual is organized into the following categories:

Preface gives information on the intended audience. It also describes the overall structure of the User Manual.

Introduction provides brief information on the overall functionality covered in the User Manual.

The subsequent chapters provide information on transactions covered in the User Manual.

Each transaction is explained in the following manner:

- Introduction to the transaction
- Screenshots of the transaction
- The images of screens used in this user manual are for illustrative purpose only, to provide improved understanding of the functionality; actual screens that appear in the application may vary based on selected browser, theme, and mobile devices.
- Procedure containing steps to complete the transaction- The mandatory and conditional fields of the transaction are explained in the procedure.

If a transaction contains multiple procedures, each procedure is explained. If some functionality is present in many transactions, this functionality is explained separately.

1.5 Related Information Sources

For more information on Oracle Banking Digital Experience Release 18.3.0.0.0, refer to the following documents:

- Oracle Banking Digital Experience Licensing Guide
- Oracle Banking Digital Experience Installation Manuals

2. Transaction Host Matrix

Legends

NH	No Host Interface Required.
✓	Pre integrated Host interface available.
×	Pre integrated Host interface not available.

Sr No	Transaction / Function Name	Third Party	Oracle FLEXCUBE Core Banking 11.7.0.0.0	Oracle FLEXCUBE Universal Banking 14.0.0.0.0 (FT/PC)	Oracle FLEXCUBE Universal Banking 14.0.0.0.0 (Oracle Banking Payments)	Oracle FLEXCUBE Universal Banking 14.1.0.0.0	Oracle FLEXCUBE Universal Banking 14.1.0.0.0 (Oracle Banking Payments)
1	Pay Bills	✓	×	×	×	×	×
2	Add Biller*	×	×	×	×	×	×
3	Manage Billers*	×	×	×	×	×	×
4	Quick Bill Pay	✓	×	×	×	×	×
5	Quick Recharge	✓	×	×	×	×	×
6	Payment History	×	×	×	×	×	×

Note: *The end to end connectivity for offline and online customer validation during "Add Biller" and related admin maintenances during "Create Biller" transactions are not part of the OBDX out of the box product offering.

[Home](#)

3. Electronic Bill Presentment And Payment

Electronic bill presentment and payment (EBPP) is a process that enables the billers to create, and present the bills / invoices online to their customers including corporates. This feature also enables the customers/ users to pay the bills online. The EBPP services are widely used in many areas like utility bill payment, fund transfer through net banking against various purchases of utility products and services by the users, payment to service providers, mobile/ DTH bill payment etc.

The main advantage of electronic bill presentment and payment is that users can pay their bills anytime quickly and conveniently, which saves lots of time and paper work.

[Home](#)

4. Bills

The Bill payment feature enables the corporate users to pay their utility bills online. Through this feature, corporate users are able to pay their bills quickly, securely and at their own convenience.

Billers are maintained in OBDX either manually using Biller Maintenance functionality or through a bulk file upload. All the registered billers (of all types) and bills are displayed on the screen. The billers can be of 'Presentment', 'Payment', 'Presentment and Payment' and 'Recharge' type.

The user either can pay the bills instantly or can schedule it to a later date. The user also has an option to enter the payment amount, select the payment frequency and the source account from which payment can be made.

The online banking application enables users to register and maintain the billers towards whom utility payments are to be made frequently or on a regular basis.

Prerequisites:

- Transaction access is provided to the corporate user
- Approval rule set up for corporate user to perform the actions
- Transaction working window is maintained
- Billers are maintained
- Transaction limits are assigned to the user to perform the transaction

Features supported in application

- Bill Payment

Workflow

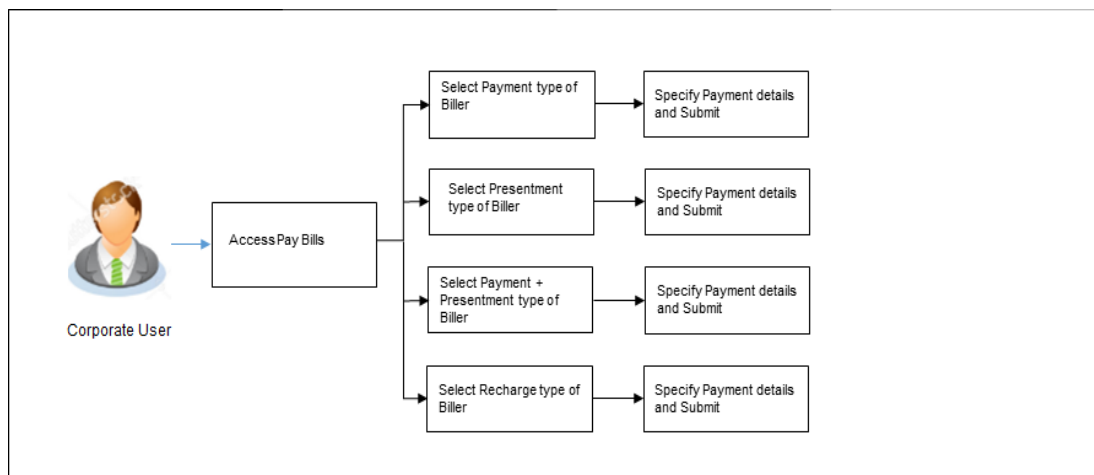

How to reach here:

Dashboard > Toggle Menu > Bill Payments > Bills

4.1 Bills - Summary

Corporate users can initiate bill payments towards billers they have already added/ registered. All billers that are previously registered are listed for selection. Once the user selects a biller, the details of that biller are populated on the screen for the user to verify. The user can proceed to initiate the bill payment transaction by specifying details such as the amount to be paid, the account from which the funds are to be transferred, and the bill date and bill number.

Bills

ZigBank
Welcome, Leo Maker
Last login 02 Nov 07:04 PM

Bills
Add Biller
Manage Bills
Quick Bill Pay
Quick Recharge
Payment History

Search By Biller Nickname, Category

[+ Add Biller](#)

Here are your bills presented

	Universal Customer Number 323132323	₹870.00 Due by 20 Aug 2018 Past Due	Pay
	homewater1 Consumer id 35456565	₹500.00 Due by 12 Sep 2018 Past Due	Pay
	homeW2 meter id 43545565	₹2,600.00 Due by 22 Sep 2018 Past Due	Pay
	EliteFitness2 MD Number 312444	No Bills Due	Pay

Here are your billers, you can pay any time

	officeMob Mobile No 9998887767		Pay
	RooyalFit Customer Number 4324234432	Auto Pay	Pay
	Alfanew6 Customer Number 43234234		Pay
	MyZetaSkyNew Customer Number 434534545	Auto Pay	Pay
	home11 Customer Number 2323434344		Pay
	SaveTheChildren Customer Number 3243243324	Auto Pay	Pay
	MyRoyalLand Customer Number TNSPPRAA	Auto Pay	Pay
	nick1 Customer Number 654321	Auto Pay	Pay
	biller Contact Number 90494		Pay

Here are your billers for recharge

	JIO Reliance JIO 1234567890		Pay
	Telenor Consumer Number 3243243243		Pay
	ClipMy Customer Number 24343		Pay

Pay bills...hassle-free

Make your bills payments & recharges hassle free with Zig Bank's Bill Payment Service. You can view all your bills in one place and plan their payments.

Pay either one bill or multiple bills in one go and set up auto payments to avoid paying bills late

And there's more...! You can receive alerts whenever a bill is presented or close to a due date.

[Quick Bill Pay](#)
[Payment History](#)



[Back to Dashboard](#)

Hey, I am here to help if you need it!

Copyright © 2006, 2017, Oracle and/or its affiliates. All rights reserved. | [Security Information](#) | [Terms and Conditions](#)

Field Description

Field Name	Description
Biller Icon	The image associated with the biller.
Biller Name	Name of the biller as maintained in the administrator biller maintenance.
Biller Labels	Biller labels maintained for which user has entered the data are displayed.
Amount	The bill amount.
Due Date	The due date of bills to be paid. If the bill due date is crossed, the 'Past Date' label is displayed. The label 'Auto Pay' is displayed against those billers for which the user has set the instructions to pay the bill on a particular date.

1. Click **Pay** against the biller for which you want to pay the bills. The **Pay Bills** screen appears.
OR
 Click  against a specific biller and then click **Manage Biller** to manage the billers. The **Manage Billers** screen appears.
OR
 Click  against a specific biller and then click **Delete Biller** to delete the billers.
OR
 Click **Add Biller** to add a new biller. The **Add Biller** screen appears.

4.2 Pay Bills - Presentment Type

Presentment type of billers presents the bill or invoice to the customer/ corporate user online before paying the bill. Bill payment feature enables users to pay their utility bills online. Through this feature, users are able to pay their bills immediately/ same business date or at some future date. The future date should be before the bill due date. The users can pay their bills from their current and savings account, Credit Cards or Debit Cards. The payment methods available for each biller is maintained as part of biller maintenance by bank administrator. The user can also partly pay or excess pay their bills (if allowed by biller, as maintained by bank administrator).

Pay Bills - Presentment Type

The screenshot displays the 'Pay Bill' page in the ZigBank mobile application. The header shows the ZigBank logo, a search icon, a notification icon with '108', and the user's name 'Welcome, Leo Maker' with a dropdown arrow. The main content area is titled 'Pay Bill' and shows details for a bill from 'homewater1' (Biller Name: PayWater, Location: Bhopal). The bill amount is €500.00, due on 12 Sep 2018. The user is logged in as 'donald' and can choose to pay 'Now' or 'Later'. A 'Bill Payments' section on the right promotes the service, highlighting features like auto-payments and alerts. The interface includes a search bar, notification icon, and user profile at the top.

Field Description

Field Name	Description
Biller Name	Name of the biller as maintained in the administrator biller maintenance.
Location	Operational area of the biller as maintained in the administrator biller maintenance.
Biller Labels	Biller labels as maintained by the bank administrator, for which user has entered the data are displayed. Only biller labels that are defined as mandatory in the administrator biller maintenance requires customers to enter the appropriate values.

Field Name	Description
Customer Name	Name of the corporate customer as maintained in biller records (entered by corporate user while adding the biller).
Note	The text displaying payment methods accepted by the biller appears on the screen. The text is maintained for biller in the administrator biller maintenance.
Pay From	The account number of the user from which payment of bill is to be done.
Balance	Net balance in the selected account.
Bill Due Date	The date on which the bill is payable.
Payment Amount	<p>The amount that is to be paid by the user.</p> <p>In the administrator biller maintenance screen if:</p> <ul style="list-style-type: none"> • Part payment flag is 'Yes': User can change the bill amount to any amount less than the initial bill amount shown. Bill amount cannot be zero. • Excess payment flag is 'Yes': User can change the bill amount to any amount more than the initial bill amount as displayed on the screen. • Part payment and Excess payment flags are set as "No": The bill amount will not be editable. • Late Payment flag is 'Yes': User is allowed to pay the bill after the due date. However even when Late payment flag is Yes, the editing of the bill amount is as per above conditions.
Pay	<p>The facility to specify when the bill payment will be processed.</p> <p>The options are:</p> <ul style="list-style-type: none"> • Now: Bill payment processed on same business day subject to processing window availability. • Later: Bill payment to be processed on a user specified future date
Scheduled Date	<p>Future date on which the bill payment will be processed.</p> <p>This field appears if you select the option Later from the Pay list.</p>

To pay a bill:

1. Click **Pay** against the biller for which you want to pay the bills. The **Pay Bills** screen appears.

Note: For 'Auto Pay' billers, a warning message that auto pay option is set for the biller appears, if the user clicks the **Pay** button.

2. From the **Pay From** list, select the source account to be debited.
3. In the **Payment Amount** field, enter the payable amount.
OR
Click the **View Limits** link to check the transfer limit.
From the **Channel** list, select the appropriate channel to view its limits. The utilized amount and the available limit appears.

View Limits

My Limits ✕

Channel ⓘ
APYODLEE ▾

Available Limits

 Amount £25.00 to £20,000.00

ⓘ Note - Above limits are derived based on your per transaction initiation limits, total available cumulative limit for the current channel, payee cooling period and payee limits set up by you if any for initiating current transaction. You may have limits available for initiating this transaction from other channel, to know more details access - [View Limits](#)

Ok

Field Description

Field Name	Description
Channel	Channel for which you the user wants to view the limits. This will be defaulted to the user logged in channel
Available Limits	
Amount	An amount range between the transactions can be initiated.

4. In the **Pay** field, select the option to indicate when the bill payment will be processed.
 - a. If you select the option **Now**, the bill payment will be processed on the same day.
OR
If you select the option **Later**, select the date on which you want to process the bill, from the **Scheduled Date** field.
5. Click **Submit**.
OR
Click **Cancel** to cancel the operation and to navigate back to 'Dashboard'.
6. The **Pay Bills - Review** screen appears. Verify the details, and click **Confirm**.
OR
Click **Cancel** to cancel the operation and to navigate back to 'Dashboard'.
OR
Click **Back** to navigate to the previous screen.
7. The success message appears along with the reference number, status and payment details.
Click **Pay Another Bill** to pay another bills.
OR
Click **Go to Dashboard**, to navigate to the dashboard.
OR
Click **Add Biller** to add the billers.

4.3 Pay Bills - Payment Type

Payment type of billers there is no bill presented online (there may be an offline bill presentation) and hence biller allows the users to pay their bills anytime using their current and savings or credit card account that is credited to the billers account. The corporate users can pay their bills immediately/ same business date or can schedule the payment. The users can set up a recurring payment by selecting payment amount and payment frequency. This option allows the user to manually enter the payment amount.

Pay Bills - Payment Type

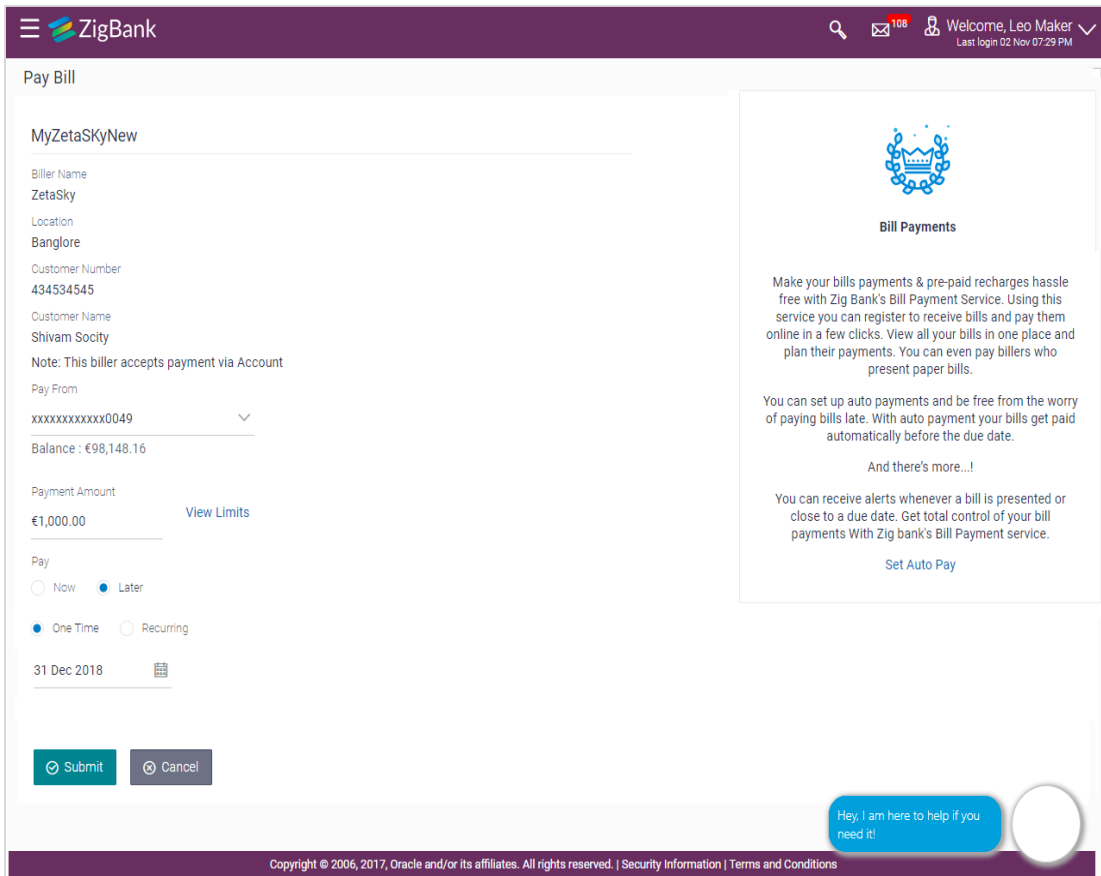

Field Description

Field Name	Description
Biller Name	Name of the biller as maintained in the administrator biller maintenance.
Location	Location of the biller as maintained in the administrator biller maintenance.
Biller Labels	Biller labels as maintained by the bank administrator, for which user has entered the data are displayed. Only biller labels that are defined as mandatory in the administrator biller maintenance requires customers to enter the appropriate values.

Field Name	Description
Customer Name	Name of the corporate customer as maintained in biller records (entered by corporate user while adding the biller).
Note	The text displaying payment methods accepted by the biller appears on the screen. The text is maintained for biller in the administrator biller maintenance.
Pay From	The account number of the user from which payment of bill is to be done.
Balance	Net balance in the selected account.
Bill Due Date	The date on which the bill is payable.
Payment Amount	The amount that is to be paid by the user.
Pay	The facility to specify when the bill payment will be processed. The options are: <ul style="list-style-type: none"> • Now: Bill payment processed on same business day subject to processing window availability. • Later: Bill payment to be processed on a user specified future date
Pay Later - One Time	Bill payment to be processed on a user specified future date. This field appears if you select the option Later in the Pay field.
Scheduled Date	Future date on which the bill payment will be processed. This field appears if you select the option One Time in the Later field.
Pay Later - Recurring	Bill payment to be processed on user specified future date and at a set frequency. This field does not appear if there is already a scheduled pay set up for the biller. This field appears if you select the option Later in the Pay field.
Start Date - End Date	The user can select future start date and end date. This field appears if you select the option Recurring in the Later field.

Field Name	Description
Select Frequency	<p>The user can set up the frequency for future bill payments.</p> <p>The user can select Start Date, End Date and frequency of payments.</p> <p>The frequency can be:</p> <ul style="list-style-type: none"> • Daily • Weekly • Fortnightly • Monthly • Bi-Monthly • Quarterly • Semi-Annually • Yearly <p>This field appears if you select the option Recurring in the Later field.</p>

To pay a bill:

1. Click **Pay** against the biller for which you want to pay the bills. The **Pay Bills** screen appears.

Note: For 'Auto Pay' billers, a warning message that auto pay option is set for the biller appears, if the user clicks the **Pay** button.

2. From the **Pay From** list, select the source account to be debited.
OR
Click the **View Limits** link to check the transfer limit.
3. In the **Payment Amount** field, enter the payable amount.
4. In the **Pay** field, select the option to indicate when the bill payment will be processed.
 - a. If you select the option **Now**, the bill payment will be processed on the same day.
OR
If you select the option **Later**, select the scheduled date to be **One Time** or **Recurring**.
If you select **One Time** option, select the Scheduled date of bill processing.
If you select **Recurring** option, select the start date, end date and frequency of recurring.
5. Click **Submit**.
OR
Click **Cancel** to cancel the operation and to navigate back to 'Dashboard'.
6. The **Pay Bills - Review** screen appears. Verify the details, and click **Confirm**.
OR
Click **Cancel** to cancel the operation and to navigate back to 'Dashboard'.
7. The success message appears along with the reference number, status and payment details.
Click **Pay Another Bill** to pay another bills.
OR
Click **Go to Dashboard**, to navigate to the dashboard.
OR
Click **Add Biller** to add the billers.

4.4 Pay Bills - Presentment and Payment Type

A Presentment and Payment type of biller has features similar to both Presentment as well as Payment type of billers. The bills/ invoice can be presented to the corporate users for bill payment or bills can be paid by the users without the invoice. In the system when the biller presents a bill he will appear in the presentment section of the Bills screen and when there is no bill presented he will appear in the Payment section of the screen. This way user can be the biller when there is a bill presented or even otherwise when there is no bill presented.

The user has can pay the bills immediately or can schedule the payment. The users can set up a recurring payment or auto payment. Both auto pay and recurring pay (scheduled payment) cannot be active at the same time.

Pay Bills - Payment and Presentment Type

Pay Bill

CosmosLTD

Biller Name
Cosmos

Location
Banglore

Customer Number
3423424

Customer Name
Denver

Note: This biller accepts payment via Account

Pay From
xxxxxxxxxxxx0049

Balance : €98,148.16

Payment Amount
€1,000.00 [View Limits](#)

Pay
 Now Later

[Submit](#) [Cancel](#)

Bill Payments

Make your bills payments & pre-paid recharges hassle free with Zig Bank's Bill Payment Service. Using this service you can register to receive bills and pay them online in a few clicks. View all your bills in one place and plan their payments. You can even pay billers who present paper bills.

You can set up auto payments and be free from the worry of paying bills late. With auto payment your bills get paid automatically before the due date.

And there's more...!

You can receive alerts whenever a bill is presented or close to a due date. Get total control of your bill payments With Zig bank's Bill Payment service.

[Set Auto Pay](#)

Hey, I am here to help if you need it!

Copyright © 2006, 2017, Oracle and/or its affiliates. All rights reserved. | [Security Information](#) | [Terms and Conditions](#)

Field Description

Field Name	Description
Biller Name	Name of the biller as maintained in the administrator biller maintenance.
Location	Operational area of the biller of the biller as maintained in the administrator biller maintenance.

Field Name	Description
Biller Labels	Biller labels as maintained by the bank administrator, for which user has entered the data are displayed. Only biller labels that are defined as mandatory in the administrator biller maintenance requires customers to enter the appropriate values.
Customer Name	Name of the corporate customer as maintained in biller records (entered by corporate user while adding the biller).
Note	The text displaying payment methods accepted by the biller appears on the screen. The text is maintained for biller in the administrator biller maintenance.
Pay From	The account number of the user from which payment of bill is to be done.
Balance	Net balance in the selected account.
Bill Due Date	The date on which the bill is payable. This field appears if bills are presented.
Payment Amount	The amount that is to be paid by the user. In the administrator biller maintenance screen if: <ul style="list-style-type: none"> • Part payment flag is 'Yes': User can change the bill amount to any amount less than the initial bill amount shown. Bill amount cannot be zero. • Excess payment flag is 'Yes': User can change the bill amount to any amount more than the initial bill amount as displayed on the screen. • Part payment and Excess payment flags are set as "No": The bill amount will not be editable. • Late Payment flag is 'Yes': User is allowed to pay the bill after the due date. However even when Late payment flag is Yes, the editing of the bill amount is as per above conditions.
Pay	The facility to specify when the bill payment will be processed. The options are: <ul style="list-style-type: none"> • Now: Bill payment processed on same business day subject to processing window availability. • Later: Bill payment to be processed on a user specified future date
Pay Later - One Time	Bill payment to be processed on a user specified future date. This field appears if you select the option Later in the Pay field.

Field Name	Description
Scheduled Date	<p>Future date on which the bill payment will be processed.</p> <p>This field appears if you select the option One Time in the Later field.</p>
<p>Following fields appear if the biller does not present bills.</p>	
Pay Later - Recurring	<p>Bill payment to be processed on user specified future date and at a set frequency.</p> <p>This field does not appear if there is already a scheduled pay set up for the biller.</p> <p>This field appears if you select the option Later in the Pay field.</p>
Start Date - End Date	<p>The user can select future start date and end date.</p> <p>This field appears if you select the option Recurring in the Later field.</p>
Select Frequency	<p>The user can set up the frequency for future bill payments.</p> <p>The user can select Start Date, End Date and frequency of payments.</p> <p>The frequency can be:</p> <ul style="list-style-type: none"> • Daily • Weekly • Fortnightly • Monthly • Bi-Monthly • Quarterly • Semi-Annually • Yearly <p>This field appears if you select the option Recurring in the Later field.</p>

To pay a bill:

1. Click **Pay** against the biller for which you want to pay the bills. The **Pay Bills** screen appears.

Note: For 'Auto Pay' billers, a warning message that auto pay option is set for the biller appears, if the user clicks the **Pay** button.

2. From the **Pay From** list, select the source account to be debited.
OR
Click the **View Limits** link to check the transfer limit.
3. In the **Payment Amount** field, enter the payable amount.
4. In the **Pay** field, select the option to indicate when the bill payment will be processed.
 - a. If the bills are presented:
 - i. If you select the option **Now**, the bill payment will be processed on the same day.
OR

If you select the option **Later**, select the date on which you want to process the bill, from the **Scheduled Date** field.

- b. If the bills are not presented:
 - i. If you select the option **Later**, select the scheduled date to be **One Time** or **Recurring**.
If you select **One Time** option, select the Scheduled date of bill processing.
If you select **Recurring** option, select the start date, end date and frequency of recurring.
5. Click **Submit**.
OR
Click **Cancel** to cancel the operation and to navigate back to 'Dashboard'.
6. The **Pay Bills - Review** screen appears. Verify the details, and click **Confirm**.
OR
Click **Cancel** to cancel the operation and to navigate back to 'Dashboard'.
7. The success message appears along with the reference number, status and payment details.
Click **Pay Another Bill** to pay another bills.
OR
Click **Go to Dashboard**, to navigate to the dashboard.
OR
Click **Add Biller** to add the billers.

4.5 Pay Bills - Recharge Type

Recharge type biller allows corporate users to do “Recharge” their prepaid services like Mobile, DTH or Internet. The user can re-charge by selecting a “plan” offered by the biller or top –up/ add money to an existing plan.

Pay Bills - Recharge Type

Field Description

Field Name	Description
Biller Name	Name of the biller as maintained in the administrator biller maintenance.
Location	Operational area of the biller of the biller as maintained in the administrator biller maintenance.
Biller Labels	Biller labels as maintained by the bank administrator, for which user has entered the data are displayed. Only biller labels that are defined as mandatory in the administrator biller maintenance requires customers to enter the appropriate values.

Field Name	Description
Customer Name	Name of the corporate customer as maintained in biller records (entered by corporate user while adding the biller).
Note	The text displaying payment methods accepted by the biller appears on the screen. The text is maintained for biller in the administrator biller maintenance.
Pay From	The account number of the user from which payment of bill is to be done.
Balance	Net balance in the selected account.
Select Plan	The option to select a recharge plan.
Recharge Amount	The amount is populated, depending on the type of plan selected by the user from the Select Plan list. Alternatively, user can also manually enter the amount he wants to top-up/add to his existing pre-paid plan.
Pay	The facility to specify when the bill payment will be processed. The options are: <ul style="list-style-type: none"> • Now: Bill payment processed on same business day subject to processing window availability. • Later: Bill payment to be processed on a user specified future date
Pay Later - One Time	Bill payment to be processed on a user specified future date. This field appears if you select the option Later in the Pay field.
Scheduled Date	Future date on which the bill payment will be processed. This field appears if you select the option One Time in the Later field.
Pay Later - Recurring	Bill payment to be processed on user specified future date and at a set frequency. This field does not appear if there is already a scheduled pay set up for the biller. This field appears if you select the option Later in the Pay field.
Start Date - End Date	The user can select future start date and end date. This field appears if you select the option Recurring in the Later field.

Field Name	Description
Select Frequency	<p>The user can set up the frequency for future bill payments.</p> <p>The user can select Start Date, End Date and frequency of payments.</p> <p>The frequency can be:</p> <ul style="list-style-type: none"> • Daily • Weekly • Fortnightly • Monthly • Bi-Monthly • Quarterly • Semi-Annually • Yearly <p>This field appears if you select the option Recurring in the Later field.</p>

To pay a bill:

1. Click **Pay** against the biller for which you want to pay the bills. The **Pay Bills** screen appears.
2. From the **Pay From** list, select the source account to be debited.
OR
Click the **View Limits** link to check the transfer limit.
3. From the **Select Plan** list, select the plan suitable to you.
The **Recharge Amount** field is populated depending on the selected plan.
OR
In the **Recharge Amount** field, enter the amount for recharge, if you have not selected any plan.
4. In the **Pay** field, select the option to indicate when the bill payment will be processed.
 - a. If you select the option **Now**, the bill payment will be processed on the same day.
OR
If you select the option **Later**, select the scheduled date to be **One Time** or **Recurring**.
If you select **One Time** option, select the Scheduled date of bill processing.
If you select **Recurring** option, select the start date, end date and frequency of recurring.
5. Click **Submit**.
OR
Click **Cancel** to cancel the operation and to navigate back to 'Dashboard'.
6. The **Pay Bills - Review** screen appears. Verify the details, and click **Confirm**.
OR
Click **Back** to navigate back to the previous screen.
OR
Click **Cancel** to cancel the operation and to navigate back to 'Dashboard'.
7. The success message appears along with the reference number, status and payment details.
Click **Pay Another Bill** to pay another bills.
OR
Click **Go to Dashboard**, to navigate to the dashboard.

OR
Click **Add Biller** to add the billers.

FAQs

1. What is Electronic Bill Presentment and Payment (EBPP)?

Electronic Bill Presentment and Payment, the process by which companies send their bills to the customers and receive payments electronically. Users can pay their bills using current and savings account/ credit card or debit card.

2. Can I initiate future dated bill payments?

Yes, you can initiate future dated bill payments by using the “Pay Later” option under bill payment. Availability of this feature depends on whether the biller allows such payments.

3. Can I do part payment or excess payment to the biller?

Part payment and excess payment can be done only if it is allowed by biller, as maintained by bank administrator in Biller Maintenance screen.

4. Can I make a payment towards a biller who is currently not registered in my biller list?

Yes, using “Quick Bill Pay” functionality you can pay a bill without registering the biller provided the biller allows such payments.

5. Can I set an option to auto pay the bill amount of already generated bills?

Yes, you can set up auto pay for any bill that is presented and is not yet paid.

[Home](#)

5. Add Biller

The online banking application enables the corporate user to add billers of the specific categories for the payment of bills and prepaid recharge electronically. Following types of billers are added.

- **Presentment Type:** Billers presents the bill or invoice to the customer/ user online before paying the bill
- **Payment Type:** Biller does not present bills. Biller allows the users to pay their bills anytime using their current and savings or credit card account that is credited to the billers account
- **Presentment and Payment Type:** Billers has features similar to both Presentment as well as Payment type of billers. The bills/ invoice can be presented to the users for bill payment or the users can pay bills without the invoice
- **Recharge Type:** Billers allows users to do “Recharge” their prepaid services like Mobile, DTH or Internet

Corporate users can create billers by specifying the Nickname of the biller(nickname should be unique), biller specific single /multiple unique customer IDs e.g. Relationship no, Account number etc., and other Biller labels as maintained in the Biller Maintenance administration screen. Multiple but unique registrations with the same biller are allowed.

Prerequisites:

- Transaction access is provided to the corporate user
- Approval rule set up for corporate user to perform the actions
- Billers are maintained in host system
- Admin Biller Category maintenance is done

Features supported in the application

- Create Biller

Workflow

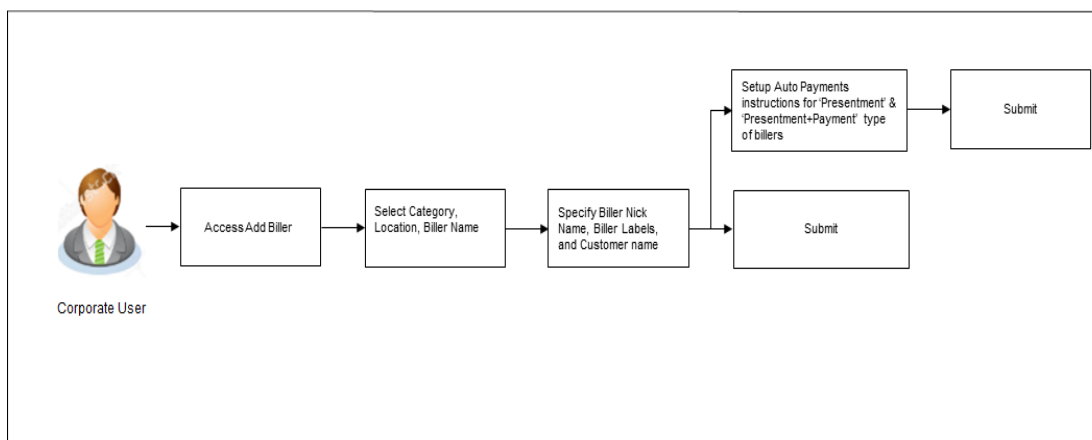

How to reach here:

Dashboard > Toggle Menu > Bill Payments > Add Billers

OR

Dashboard > Toggle Menu > Bill Payments > Bills > Add Billers

Add Biller

Add Biller

Category: Entertainment

Location: Banglore

Biller Name: Universal Stud

Biller Type: Presentment

Biller Nickname (Nickname should be unique): Universal

Customer Number: 123323 [Sample Bill](#)

Universal Number: 354545

Customer Name (As mentioned in biller's record): John Smith

Auto Pay: Yes No

Note: This biller accepts payment via Account

Pay From: xxxxxxxxxxxx0049

Pay: Bill Amount Limit Amount

£1,000.00

Auto pay will not be attempted for more than amount mentioned

[Back to Dashboard](#)

Decided to make online bill payment? Great!

The first step is to add billers who you want to pay. Once billers validate your registration you are all set to pay bills. You can even add billers who give paper bills and pay them online.

Zig Bank's Bill Payment Service makes online bill payment & recharges hassle free.

[View Bills](#)
[Payment History](#)

Hey, I am here to help if you need it!

Copyright © 2006, 2017, Oracle and/or its affiliates. All rights reserved. | [Security Information](#) | [Terms and Conditions](#)

Field Description

Field Name	Description
Category	The category of the registered biller.

Field Name	Description
Location	Operational area of the biller of the biller as maintained in the administrator biller maintenance.
Biller Name	Name of the biller as maintained in the administrator biller maintenance.
Biller Type	On selecting the biller name, the biller type is displayed. The biller type can be: <ul style="list-style-type: none"> • Presentment: Biller is of Presentment type • Payment: Biller is of Payment type • Presentment and Payment: Biller is of Presentment and Payment type • Recharge: Biller is of Recharge type
Biller Nickname	Nickname of the biller. The nickname has to be unique i.e. same nickname cannot be used for more than one biller.
Sample Bill	Link to upload the image of the physical bill presented by the biller. This field appears for ' Presentment ' and ' Presentment and Payment ' type of billers.
Biller Labels	Biller labels as maintained by the bank administrator, for which user has entered the data are displayed. Only biller labels that are defined as mandatory in the administrator biller maintenance requires customers to enter the appropriate values.
Customer Name	Name of the corporate customer as maintained in biller records (entered by corporate user while adding the biller).
Following fields appears for ' Presentment ' and ' Presentment and Payment ' type of billers.	
Auto Pay	The facility to automatic pay the bills on the specified date. The options are: <ul style="list-style-type: none"> • Yes • No This feature is available for Presentment and Presentment & Payment type billers only.
Note	The text displaying payment methods accepted by the biller appears on the screen. The text is maintained for biller in the administrator biller maintenance. This field appears if you select Yes option in the Auto Pay field.

Field Name	Description
Pay From	The account number of the user from which payment of bill is to be done. This field appears if you select Yes option in the Auto Pay field.
Pay	Indicates the current selection for bill pay amount. The options are: <ul style="list-style-type: none"> • Bill Amount: Whether the user want to pay full bill amount. • Limit Amount: Whether the user want to pay the limit amount. This field appears if you select Yes option in the Auto Pay field.
Limit Amount	The limit amount the user wants to pay to schedule the auto payment.

To add a biller:

1. From the **Category** list, select the category of the biller.
2. From the **Location** list, select the category of the biller.
3. From the **Biller Name** list, select the registered biller name.
4. In the **Biller Nickname** field, enter the biller nickname.
5. In the **Biller Label 1, 2 and 3**, enter the required details.
6. In the **Customer Name** field, enter the name of the customer.
7. If you have selected the **Presentment** or **Presentment or Payment** type of biller from the **Biller Name** list:
 - a. From the **Auto Pay** list, select the appropriate option;
Select option **Yes** to set up auto payment.
OR
Select the option **No**, if you do not want to set the auto payment and go to step 6 to continue to add billers process.
 - b. From the **Pay From** list, select the source account/ debit card / credit card to be debited.
 - c. In the **Pay** field, you can enter the entire bill amount in the **Bill Amount** field, or enter the limit amount in the **Limit Amount** field.
8. Click **Submit** to add a biller.
OR
Click **Cancel** to cancel the operation and navigate back to 'Dashboard'.
OR
Click **Back to Dashboard**, to navigate back to the dashboard.
9. The **Add Biller - Review** screen appears. Verify the details, and click **Confirm**.
OR
Click **Back** to navigate back to the previous screen.
OR
Click **Cancel** to cancel the operation and to navigate back to 'Dashboard'.
10. The success message appears along with the reference number, status and biller details.
Click **Pay Bills** to pay the bills.

OR

Click **View Bills** to view the bills.

OR

Click **Add More Biller** to add more billers.

OR

Click **Go to Dashboard**, to navigate to the dashboard.

FAQs

1. **Can I delete billers that I no longer need to make payments to?**

Yes, you can choose to delete the billers that you no longer need.

2. **When can I make the payment to newly added biller?**

After successfully adding a biller, you may proceed to pay bills towards the specific biller immediately. However, some billers need to validate your registration in which case you can start paying the biller after a successful validation.

3. **If I delete or edit a biller, what will happen to the in-flight transactions?**

Billers modification or deletion will not have any impact on the transactions which are initiated towards the payee and that are pending further processing.

[Home](#)

6. Manage Billers

Billers are maintained in OBDX either manually using Biller Maintenance functionality or through a bulk file upload.

The online banking application enables corporate users to maintain the billers towards whom utility payments are to be made frequently or on a regular basis. Manage biller functionality allows the users to modify and delete the details of the registered billers. Following details of the registered billers can be modified:

- Nickname
- Auto pay details: Change Bill Amount/ Limit Amount choice, Edit existing Bill Amount, Change Source of funds
- Scheduled Bill Payment/ Recharge: Modify Payment Amount, Specific Date (before the payment date)
- Scheduled Bill Payment/ Recharge - Recurring: Modify Payment Amount, Start and End Dates, Payment Frequency

Prerequisites:

- Transaction access is provided to the corporate user
- Approval rule set up for corporate user to perform the actions
- Billers are maintained in host system
- Admin Biller Maintenance is done

Features supported in the application

- Modify Biller
- Delete Biller

Workflow

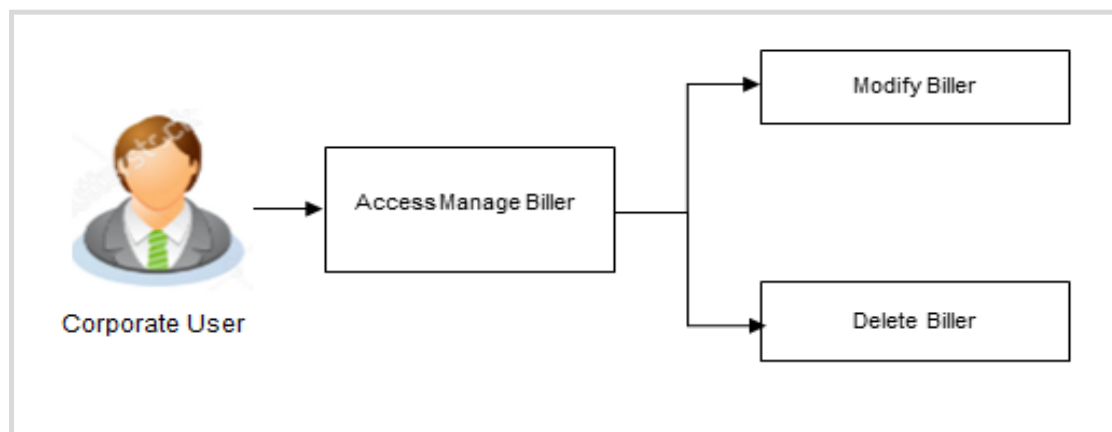

How to reach here:

Dashboard > Toggle Menu > Bill Payments > Manage Billers

OR

Dashboard > Toggle Menu > Bill Payments > Bills > Manage Billers

Manage Billers

Field Description

Field Name	Description
Select Biller	The user has to select a biller for bill payments.
Category	The category of the registered biller.

Field Name	Description
Location	Location of the biller as maintained in the administrator biller maintenance.
Biller Name	Name of the biller as maintained in the administrator biller maintenance.
Biller Type	On selecting the biller, the biller type is displayed. The biller type can be: <ul style="list-style-type: none"> • Presentment: Biller is of Presentment type • Payment: Biller is of Payment type • Presentment and Payment: Biller is of Presentment and Payment type • Recharge: Biller is of Recharge type
Biller Nickname	Nickname of the biller.
Biller Labels	Biller labels as maintained by the bank administrator, for which user has entered the data are displayed. Only biller labels that are defined as mandatory in the administrator biller maintenance requires customers to enter the appropriate values.
Customer Name	Name of the corporate customer as maintained in biller records (entered by corporate user while adding the biller).
Following fields appears for Presentment type of billers.	
Auto Pay	The facility to automatic pay the bills on the specified date. The options are: <ul style="list-style-type: none"> • Yes • No <p>This feature is available for “Payment Type” and “presentment and Payment” type billers only. In case of “Presentment and Payment” type billers either Auto Pay or Scheduled Pay feature will be available.</p>
Note	The text displaying payment methods accepted by the biller appears on the screen. The text is maintained for biller in the administrator biller maintenance. This field appears if you select Yes option in the Auto Pay field.
Pay From	The account number of the user from which payment of bill is to be done. This field appears if you select Yes option in the Auto Pay field.

Field Name	Description
Pay	<p>Indicates the current selection for bill pay amount.</p> <p>The options are:</p> <ul style="list-style-type: none"> • Bill Amount: Whether the user want to pay full bill amount. • Limit Amount: Whether the user want to pay the limit amount. <p>This field appears if you select Yes option in the Auto Pay field.</p> <p>Following fields appears for Presentment and Payment type of billers.</p> <p>For Presentment and Payment type of billers user can setup either a Scheduled Pay or Auto Pay. Both can not be set up at the same time.</p>
Auto Pay	<p>The facility to automatic pay the bills on the specified date.</p> <p>The options are:</p> <ul style="list-style-type: none"> • Yes – If Auto Pay is set up for a biller, this flag will be maintained as yes. User can stop/cancel the ongoing autopay by changing this flag to No • No – Indicates that auto pay has not been set up for the biller
Note	<p>The text displaying payment methods accepted by the biller appears on the screen. The text is maintained for biller in the administrator biller maintenance.</p> <p>This field appears if you select Yes option in the Auto Pay field.</p>
Pay From	<p>The account number of the user from which payment of bill is to be done.</p> <p>This field appears if you select Yes option in the Auto Pay field.</p>
Pay	<p>Indicates the current selection for bill pay amount.</p> <p>The options are:</p> <ul style="list-style-type: none"> • Bill Amount: Whether the user want to pay full bill amount. • Limit Amount: Whether the user want to pay the limit amount. <p>.This field appears if you select Yes option in the Auto Pay field.</p> <p>The Scheduled Pay section is enabled if you select, No option in the Auto Pay field.</p>

Field Name	Description
Scheduled Pay	<p>The facility to specify if the bill payment is scheduled or not.</p> <p>The options are:</p> <ul style="list-style-type: none"> • Yes: If Scheduled Pay is set up for a biller, this flag will be maintained as yes. User can stop/cancel the ongoing scheduled pay by changing this flag to No • No: Indicates that scheduled pay has not been set up for the biller <p>In case of Presentment & Payment type billers either Auto Pay or Scheduled Pay feature will be available.</p>
Note	<p>The text displaying payment methods accepted by the biller appears on the screen. The text is maintained for biller in the administrator biller maintenance.</p> <p>This field appears if you select Yes option in the Schedule Pay field.</p>
Pay From	<p>The account number of the user from which payment of bill is to be done.</p> <p>This field appears if you select Yes option in the Schedule Pay field.</p>
Amount	<p>The amount that is to be paid by the user.</p>
Scheduled Date	<p>Future date on which the bill payment will be processed.</p> <p>This field appears if you select Yes option in the Schedule Pay field.</p>
<p>Following fields appears for Payment and Recharge type of billers.</p>	
Scheduled Pay	<p>The facility to specify if the bill payment is scheduled or not.</p> <p>The options are:</p> <ul style="list-style-type: none"> • Yes: Bill payment to be processed on a user specified future date • No: Bill payment processed on same business day subject to processing window availability.
Note	<p>The text displaying payment methods accepted by the biller appears on the screen. The text is maintained for biller in the administrator biller maintenance.</p> <p>This field appears if you select Yes option in the Schedule Pay field.</p>
Pay From	<p>The account number of the user from which payment of bill is to be done.</p> <p>This field appears if you select Yes option in the Schedule Pay field.</p>
Select Plan	<p>Option to select a plan.</p> <p>This field appears for Recharge type of biller</p>

Field Name	Description
Amount	The amount that is to be paid by the user.
Payment Type	<p>The facility to specify when the bill payment will be processed.</p> <p>The options are:</p> <ul style="list-style-type: none"> • One Time: Bill payment to be processed on a user specified future date. • Recurring: Bill payment to be processed on user specified future date and at a set frequency.
Scheduled Date	<p>Future date on which the bill payment will be processed.</p> <p>This field appears if you select the option One Time in the Payment Type field.</p>
Start Date - End Date	<p>The user can select future start date and end date.</p> <p>This field appears if you select the option Recurring in the Payment Type field.</p>
Select Frequency	<p>The user can set up the frequency for future bill payments.</p> <p>The user can select Start Date, End Date and frequency of payments.</p> <p>The frequency can be:</p> <ul style="list-style-type: none"> • Daily • Weekly • Fortnightly • Monthly • Bi-Monthly • Quarterly • Semi-Annually • Yearly <p>This field appears if you select the option Recurring in the Payment Type field.</p>

To manage billers:

1. From the **Select Biller** list, select the appropriate **Biller**.
2. In the **Biller Nickname** field, modify the biller nickname if required.
3. If you have selected the **Presentment** type of biller from the **Select Biller** list:
 - a. From the **Auto Pay** list, select the appropriate option; Select option **Yes** to set up auto payment.
OR

Select the option **No**, if you do not want to set the auto payment and go to step 6 to continue to manage billers.

- b. From the **Pay From** list, select the source account/ debit card / credit card to be debited.
 - c. In the **Pay** field, you can enter the entire bill amount in the **Bill Amount** field, or enter the limit amount in the **Limit Amount** field.
4. If you have selected the **Payment and Presentment** type of biller from the **Select Biller** list:
If you want to set up **Auto Payment**:
- a. From the **Auto Pay** list, select the **Yes** option.
 - b. From the **Pay From** list, select the source account/ debit card / credit card to be debited.
 - c. In the **Pay** field, you can enter the entire bill amount in the **Bill Amount** field, or enter the limit amount in the **Limit Amount** field.

OR

If you want to set up **Schedule Payment**:

- a. From the **Schedule Pay** list, select the **Yes** option.
 - b. From the **Pay From** list, select the source account to be debited.
 - c. In the **Amount** field, enter the bill amount.
 - d. In the **Payment Type** field, select the appropriate option:
 - i. If you select **One Time** option, select the future date from the **Scheduled Date** list.
 - ii. If you select **Recurring** option, select the future start date, end date and frequency of recurrence.
5. If you have selected the **Payment** or **Recharge** type of biller from the **Select Biller** list.
- a. From the **Schedule Pay** list, select the appropriate option;
Select option **Yes** to set up schedule payment.
OR
Select the option **No**, if you do not want to set the schedule payment and go to step 6 to continue to manage billers.
 - b. From the **Pay From** list, select the source account to be debited.
 - c. In the **Amount** field, enter the bill amount.
OR
From the **Select Plan** list, select the plan suitable to you.
The **Recharge Amount** field is populated depending on the selected plan.
 - d. In the **Payment Type** field, select the appropriate option:
 - i. If you select **One Time** option, select the future date from the **Scheduled Date** list.
 - ii. If you select **Recurring** option, select the future start date, end date and frequency of recurrence.

6. Click **Submit**.

OR

Click **Delete** to delete the biller maintenance.

OR

Click **Cancel** to cancel the transaction.

7. The **Review** screen appears. Verify the details, and click **Confirm**.

OR

Click **Cancel** to cancel the transaction.

OR

Click **Back** to navigate to the previous page.

OR

Click **Back to Dashboard**, to navigate back to the dashboard.

- The success message appears along with the reference number, status and biller details.

Click **Pay Bills** to pay the bills.

OR

Click **View Bills** to view the bills.

OR

Click **Add More Biller** to add the billers.

OR

Click **Go to Dashboard**, to navigate to the dashboard.

6.2 Manage Billers - Delete

Using this option, you can delete the registered biller.

To delete a biller:

- Navigate to the **Manage Billers** screen.

OR

In the **Bills** screen Click  option against a specific Biller which you want to delete, and then click **Delete Biller**

- From the **Select Biller** list, select the appropriate **Biller**.

- Click **Delete**. The **Delete Biller** pop up window appears with a warning message prompting the user to confirm the deletion.

Delete Biller

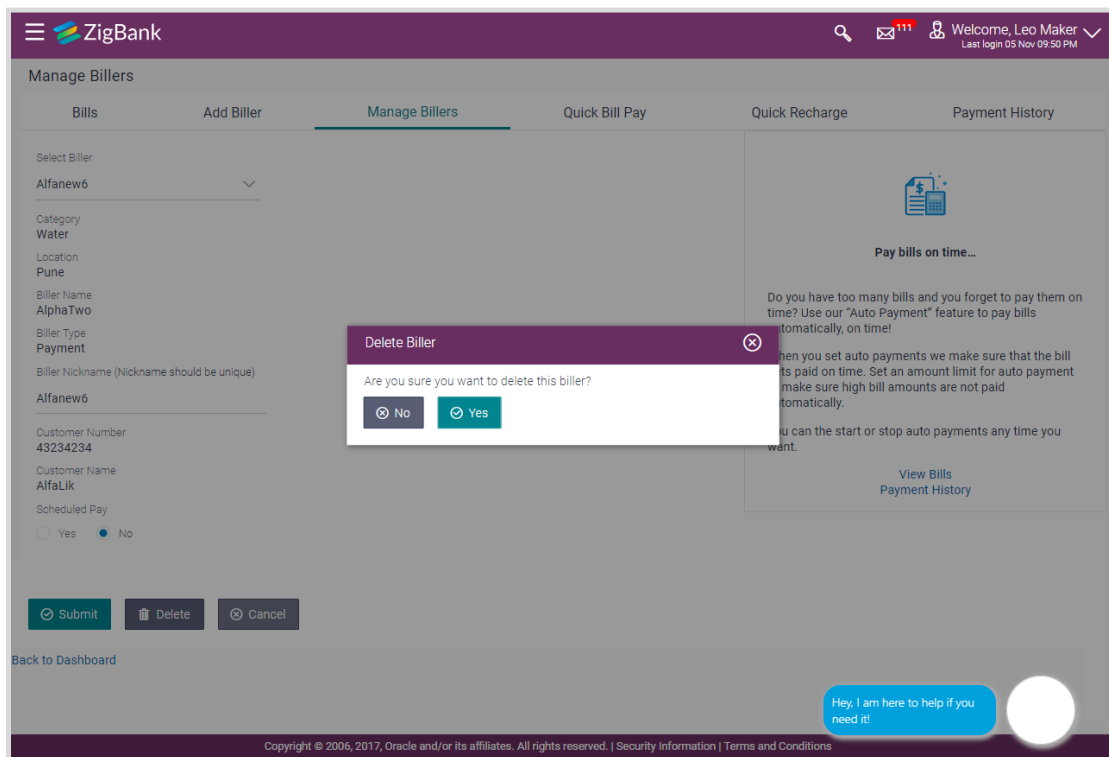

The screenshot shows the ZigBank 'Manage Billers' interface. A 'Delete Biller' dialog box is displayed in the foreground, asking 'Are you sure you want to delete this biller?' with 'No' and 'Yes' buttons. The background shows the 'Manage Billers' screen with a 'Select Biller' dropdown set to 'Alfanew6', category 'Water', location 'Pune', and biller name 'AlphaTwo'. The dialog box also contains a warning message about auto payments.

4. Click **Yes** to proceed with the deletion request.
OR
Click **No** to cancel the deletion process.
5. The screen confirming biller deletion appears.
Click **Go to Dashboard** to navigate to the dashboard.
OR
Click **More Payment Options** to access other payment options.

FAQs

1. **Can I delete billers that I no longer need to make payments to?**

Yes, you can choose to delete the billers that you no longer need.

2. **When can I make the payment to newly added biller?**

After successfully adding a biller, you may proceed to pay bills towards the specific biller immediately.

3. **If I delete or edit a biller, what will happen to the in-flight transactions?**

Biller modification or deletion will not have any impact on the transactions which are initiated towards the payee and that are pending further processing.

[Home](#)

7. Quick Bill Pay

The Quick Bill payment feature enables the corporate users to pay their utility bills online without registration. Through this feature, users are able to pay their bills quickly, securely and at their own convenience.

The user can initiate bill payment transactions to 'Payment' and 'Presentment and Payment' type of billers who allow Quick payment.

The user also has an option to enter the payment amount, select the recharge plan, the source of funds from which payment can be made, and the date on which payment can be made.

Prerequisites:

- Transaction access is provided to the corporate user
- Approval rule set up for corporate user to perform the actions
- Transaction working window is maintained
- Billers are maintained
- Transaction limits are assigned to the user to perform the transaction

Features supported in application

- Quick Bill payment

Workflow

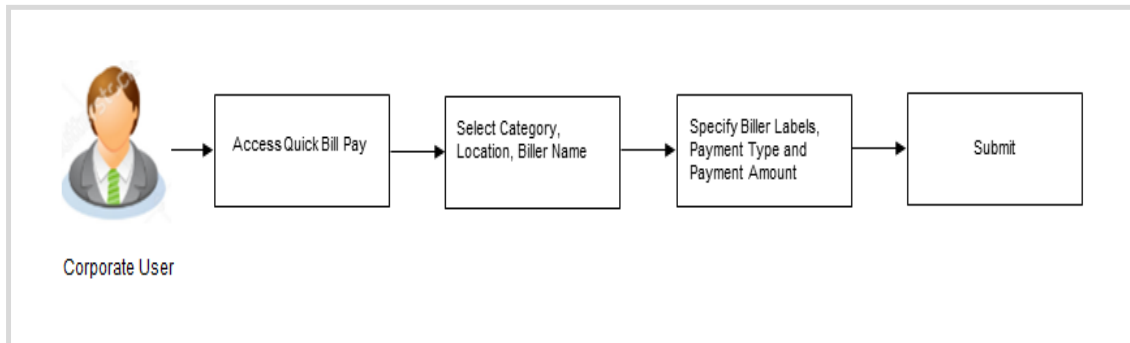

How to reach here:

Dashboard > Toggle Menu > Bill Payments > Quick Bill Pay

OR

Dashboard > Toggle Menu > Bill Payments > Bills > Quick Bill Pay

Quick Bill Pay

Quick Bill Pay

Category: SocialWelfare

Location: Banglore

Biller Name: SiliconSt

Biller Type: Presentment and Payment

Customer Number: 6444666

Customer Name (As mentioned in biller's record): John Smith

Note: This biller accepts payment via Account

Pay From: xxxxxxxxxxxx0049

Balance: €98,148.16

Payment Amount: €1,000.00

View Limits

Pay: Now Later

29 Nov 2018

[Submit](#) [Cancel](#)

[Back to Dashboard](#)

In a rush to pay bills?

Pay bills now

No need to register with a biller to pay them online. With Quick Bill Pay, you can pay a biller without registering Zig Bank's Bill Payment Service makes online bill payment & recharges hassle free

[Add Biller](#)
[Payment History](#)

Hey, I am here to help if you need it!

Copyright © 2006, 2017, Oracle and/or its affiliates. All rights reserved. | [Security Information](#) | [Terms and Conditions](#)

Field Description

Field Name	Description
Category	The list of biller categories as maintained in the administrator biller maintenance.
Location	Location of the biller as maintained in the administrator biller maintenance.
Biller Name	Name of the biller as maintained in the administrator biller maintenance.
Biller Type	On selecting the biller name, the biller type is displayed as maintained in the administrator biller maintenance.
Biller Labels	Unique ID or relationship number provided by biller for customer identification. Example: Mobile No./ Account No. etc.

Field Name	Description
Sample Bills	Link to view the sample bill. This link appears only for 'Presentment' and 'Payment and Presentment' type of billers.
Customer Name	Name of the corporate customer as maintained in biller records (entered by corporate user while adding the biller).
Note	The text displaying payment methods accepted by the biller appears on the screen. The text is maintained for biller in the administrator biller maintenance.
Pay From	The account number of the user from which payment of bill is to be done.
Balance	Net balance in the selected account.
Payment Amount	The amount that is to be paid by the user as quick bill payment.
View Limits	The link to view the user limit.
Pay	The facility to specify when the bill payment will be processed. The options are: <ul style="list-style-type: none"> • Now: Bill payment processed on same business day subject to processing window availability. • Later: Bill payment to be processed on a user specified future date
Scheduled Date	Future date on which the bill payment will be processed. This field appears if you select the option Later from the Pay list.

To pay a bill:

1. From the **Category** list, select the category of the biller.
2. From the **Location** list, select the category of the biller.
3. From the **Biller Name** list, select the registered biller name.
4. In the **Biller Label 1, 2 and 3**, enter the relationship of the user with the biller.
For example: In the **Mobile Number** field, enter the mobile number of the customer.
5. In the **Customer Name** field, enter the name of the customer.
6. From the **Pay From** list, select the source account to be debited.
7. In the **Payment Amount** field, or enter the bill amount to be paid.
OR
Click the **View Limits** link to check the transfer limit.
From the **Channel** list, select the appropriate channel to view its limits. The utilized amount and the available limit appears.

View Limits

My Limits ✕

Channel ⓘ
APYODLEE ▼

Available Limits



Amount

£25.00 to £20,000.00

ⓘ Note - Above limits are derived based on your per transaction initiation limits, total available cumulative limit for the current channel, payee cooling period and payee limits set up by you if any for initiating current transaction. You may have limits available for initiating this transaction from other channel, to know more details access - View Limits

Ok

Field Description

Field Name	Description
Channel	Channel for which you the user wants to view the limits. This will be defaulted to the user logged in channel
Available Limits	
Amount	An amount range between the transactions can be initiated.

8. In the **Pay** field, select the option to indicate when the bill payment will be processed.
 - a. If you select the option **Now**, the bill payment will be processed on the same day.
OR
If you select the option **Later**, select the date on which you want to process the bill, from the **Scheduled Date** field.
9. Click **Submit**.
OR
Click **Cancel** to cancel the operation and to navigate back to 'Dashboard'.
OR
Click **Back to Dashboard**, to navigate back to the dashboard.
10. The **Quick Bill Pay - Review** screen appears. Verify the details, and click **Confirm**.
OR
Click **Cancel** to cancel the operation and to navigate back to 'Dashboard'.
OR

Click **Back** to navigate back to the previous screen.

OR

Click **Back to Dashboard**, to navigate back to the dashboard.

11. The success message appears along with the reference number, status and payment details.

Click **Pay Another Bill** to pay another bills.

OR

Click **Go to Dashboard**, to navigate to the dashboard.

OR

Click **Add Biller** to add the billers.

FAQs

1. Why I have to use "Quick Bill Pay"?

Quick bill payment allows the user to pay the bills quickly, securely and conveniently without registering the billers.

2. Is payment through "Quick Bill Pay" secure?

Yes, the bill payments through quick bill pay is completely secure.

3. Is there any limit to the number of bills you can pay using the "Quick Bill Pay" feature?

There is no limit to the numbers of bills you can pay through the "Quick Bill Pay" feature.

4. Can I initiate a payment towards any biller using the "Quick Bill Pay"?

No, using this transaction, you can make payment only to the 'Payment' and 'Presentment and Payment' type' of billers.

[Home](#)

8. Quick Recharge

The Quick recharge feature enables the corporate users to initiate bill payments without registering the billers to the 'Recharge' type billers.

The user either can pay the bills immediately /same business date or can schedule it to a later date. The user also has options to set up a recurring pre-paid recharge to the biller, stop the ongoing recurring pay (scheduled pay) and modify an existing active recurring payment (scheduled payment).

The user can select the source of funds as allowed by the biller (maintained by bank administrator) like current and savings bank account, credit card or debit card.

Prerequisites:

- Transaction access is provided to the corporate user
- Approval rule set up for corporate user to perform the actions
- Transaction working window is maintained
- Billers are maintained
- Transaction limits are assigned to the user to perform the transaction

Features supported in application

- Quick Recharge

Workflow

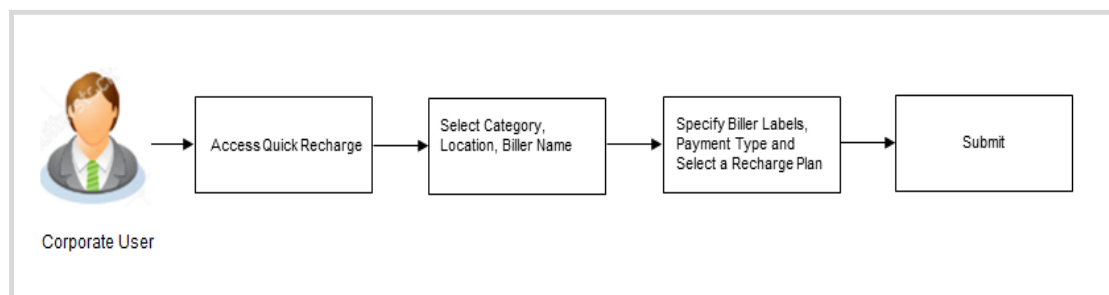

How to reach here:

Dashboard > Toggle Menu > Bill Payments > Quick Recharge

Quick Recharge

Quick Recharge

Category: Entertainment

Location: Agra

Biller Name: Nrecharge

Client Id: 122

Date of onboarding: 12Nov18

Customer Name (As mentioned in biller's record): John Smith

Note: This biller accepts payment via Account

Pay From: xxxxxxxxxxxx0049

Select Plan: Vodafone New Freedom 149 Per S...

Recharge Amount: £149.00

View Limits

Pay: Now Later

30 Nov 2018

[Submit](#) [Cancel](#)

[Back to Dashboard](#)

Recharge

Pre-paid recharges now made easy with Zig Bank's Bill Payment Service. Now you can recharge your pre-paid services like mobile, DTH or internet etc in your online/mobile banking.

Select the service provider, select a plan or an amount to recharge and pay...recharge online with the click of a few buttons.

You can even set up recurring payments to recharge on a set frequency like weekly or monthly.

[View Bills](#)
[Payment History](#)

Copyright © 2006, 2017, Oracle and/or its affiliates. All rights reserved. | [Security Information](#) | [Terms and Conditions](#)

Field Description

Field Name	Description
Category	The list of biller categories as maintained in the administrator biller maintenance.
Location	Location of the biller as maintained in the administrator biller maintenance.
Biller Name	Name of the biller as maintained in the administrator biller maintenance.
Biller Labels	Unique ID or relationship number provided by biller for customer identification. Example: Mobile No./ Account No. etc.

Field Name	Description
Customer Name	Name of the corporate customer as maintained in biller records (entered by corporate user while adding the biller).
Note	The text displaying payment methods accepted by the biller appears on the screen. The text is maintained for biller in the administrator biller maintenance.
Pay From	The account number of the user from which recharge of bill is to be done.
Select Plan	The option to select a recharge plan.
Recharge Amount	The amount is populated, depending on the type of plan selected by the user from the Select Plan list. If the user had not selected any plan, he has to enter the amount.
View Limits	The link to view the user limit.
Pay	The facility to specify when the bill payment will be processed. The options are: <ul style="list-style-type: none"> • Now: Bill payment processed on same business day subject to processing window availability. • Later: Bill payment to be processed on a user specified future date
Scheduled Date	Future date on which the bill payment will be processed. This field appears if you select the option Later from the Pay list.
Pay Later - Recurring	Bill payment to be processed on user specified future date and at a set frequency. This field does not appear if there is already a scheduled pay set up for the biller. This field appears if you select the option Later in the Pay field.
Start Date - End Date	The user can select future start date and end date. This field appears if you select the option Recurring in the Later field.

Field Name	Description
Select Frequency	<p>The user can set up the frequency for future bill payments.</p> <p>The user can select Start Date, End Date and frequency of payments.</p> <p>The frequency can be:</p> <ul style="list-style-type: none"> • Daily • Weekly • Fortnightly • Monthly • Bi-Monthly • Quarterly • Semi-Annually • Yearly <p>This field appears if you select the option Recurring in the Later field.</p>

To pay a bill:

1. From the **Category** list, select the category of the biller.
2. From the **Location** list, select the category of the biller.
3. From the **Biller Name** list, select the registered biller name.
4. In the **Biller Label 1, 2 and 3**, enter the relationship of the user with the biller.
For example: In the **Consumer Number** field, enter the consumer number of the customer.
5. In the **Customer Name** field, enter the name of the customer.
6. From the **Pay From** list, select the source account to be debited.
7. From the **Select Plan** list, select the plan suitable to you.
The **Recharge Amount** field is populated depending on the selected plan.
OR
In the **Recharge Amount** field, enter the amount for recharge, if you have not selected any plan.
OR
Click the **View Limits** link to check the transfer limit.
From the **Channel** list, select the appropriate channel to view its limits. The utilized amount and the available limit appears.

View Limits

My Limits ✕

Channel (i)

APYODLEE ▼

Available Limits

Amount

£25.00 to £20,000.00

(i) Note - Above limits are derived based on your per transaction initiation limits, total available cumulative limit for the current channel, payee cooling period and payee limits set up by you if any for initiating current transaction. You may have limits available for initiating this transaction from other channel, to know more details access - [View Limits](#)

Ok

Field Description

Field Name	Description
Channel	Channel for which you the user wants to view the limits. This will be defaulted to the user logged in channel.
Available Limits	
Amount	An amount range between the transactions can be initiated.

8. In the **Pay** field, select the option to indicate when the bill payment will be processed.
 - a. If you select the option **Now**, the bill payment will be processed on the same day.
OR
If you select the option **Later**, select the scheduled date to be **One Time** or **Recurring**.
If you select **One Time** option, select the Scheduled date of bill processing.
If you select **Recurring** option, select the start date, end date and frequency of recurring.
9. Click **Submit**.
OR
Click **Cancel** to cancel the operation and to navigate back to 'Dashboard'.
10. The **Quick Bill Pay - Review** screen appears. Verify the details, and click **Confirm**.
OR
Click **Cancel** to cancel the operation and to navigate back to 'Dashboard'.
OR
Click **Back** to navigate back to the previous screen.
OR
Click **Back to Dashboard**, to navigate back to the dashboard.

11. The success message appears along with the reference number, status and payment details.
Click **Pay Another Bill** to pay another bills.
OR
Click **Go to Dashboard**, to navigate to the dashboard.
OR
Click **Add Biller** to add the billers.

FAQs

1. **Where I can use Quick Recharge"?**

You can use quick recharge to pay the bills of only 'Recharge' type of billers who allows quick recharge.

2. **Can I set up recurring payment using “Quick Recharge”?**

Yes, there is an option 'Pay Later - Recurring' to set the recurring payment of your recharge.

[Home](#)

9. Payment History

Payment history allows the corporate users to review and keep track to all the payment transactions done by him in a given period. The user can search and view his past bill payment transactions done for both registered and un-registered billers. A user can search transactions based on category and biller nickname.

The user can view the following details of past bill payment transactions in the 'Payment History' screen.

- Date of bill payment
- Name of the biller (nick name for registered billers and official name for unregistered billers)
- Category of the biller
- Bill Amount
- Reference number of the payment transaction
- Status of the bill payment transaction

Prerequisites:

- Transaction access is provided to the corporate user
- Approval rule set up for corporate user to perform the actions
- Transaction working window is maintained
- Billers are maintained
- Transaction limits are assigned to the user to perform the transaction

Features supported in application

- Payment History

How to reach here:

Dashboard > Toggle Menu > Bill Payments > Payment History

OR

Dashboard > Toggle Menu > Bill Payments > Bills > Payment History

Payment History

Payment History

Select Period
Current Period

Search By Biller, Category

Download

Date	Biller	Category	Bill Amount	Reference No	Status
06 Nov 2018	Universal Stud	Entertainment	\$870.00	1252	Completed
05 Nov 2018	Universal Stud	Entertainment	\$870.00	1251	Completed
26 Sep 2018	Netflix	Entertainment	£55.00	951	Completed
26 Sep 2018	Cosmos	SocialWelfare	£323.00	952	Completed
20 Sep 2018	Universal Stud	Entertainment	£870.00	604	Completed
17 Sep 2018	CiscoConnect	Telecom	£1,233.00	851	Completed
12 Sep 2018	CiscoConnect	Telecom	£43.00	704	Completed
12 Sep 2018	Netflix	Entertainment	£125.00	708	Completed
12 Sep 2018	SiliconSt	SocialWelfare	£123.00	711	Completed
12 Sep 2018	Airtel	Telecom	£123.00	709	Completed

Page 1 of 7 (1-10 of 62 Items)

Back to Dashboard

Notes

With Payment History get all the past bill payment & recharges records with a few click. Check whether you paid bill or not, check if the payment was on time!
You can even download or e-mail a copy of the e-receipt of your bill payment.

View Bills
Quick Recharge

Hey, I am here to help if you need it!

Copyright © 2006, 2017, Oracle and/or its affiliates. All rights reserved. | Security Information | Terms and Conditions

Field Description

Field Name	Description
Select Period	Period for which payment history search is to be executed. The options are: <ul style="list-style-type: none"> • Current Period • Previous Month • Previous Quarter • Select Date Range
From Date - To Date	The date range to view the bill payments done during the specific date. This field appears if you select Select Date Range option from the Select Period list.
Search By	The user can search a specific biller by entering the Biller Nickname or Biller Category.
Download	The user can download the payment history in csv or pdf format.

Field Name	Description
Search Results	
Date	Date on which the bill payment is made.
Billers	The nickname of the biller is displayed if the biller is a registered biller; if the biller is not registered the official name as maintained in the administrator Biller Maintenance is displayed.
Category	The category of the biller as maintained in the administrator biller maintenance.
Bill Amount	The amount paid by the user.
Reference No.	Host reference number generated at the time of the payment transaction.
Status	Status of the payment transaction

To view the payment history of the specific period:

1. From the **Select Period** list, select the appropriate transaction period.
 - a. If you have selected the **Date Range** option, select the required date from the **From Date - To Date** field and click **Search**.
The search results appear on the **Payment History** screen matching the search criteria.
2. In the **Search By** field, enter the biller **Category** or **Biller Nickname** to search the specific biller.
3. From the **Download** list, select the format in which you want to view and download the payment history.

[Home](#)

10. Alerts

Alerts are generated in case of following instances.

- When a biller is added, modified, deleted
- When a new bill is presented or paid.
- When a payment is set up, modified and cancelled/stopped

Example of Alerts

